

Set Up Instructions

DFW-3000L

Step 1: Open hard case and remove all aluminum frames and pole from foam inserts.



Step 2: Push sections together to complete each vertical side frame.

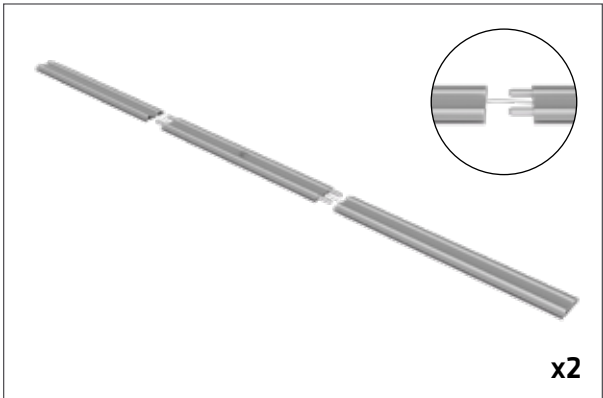

Step 3: Add 4 corners to the two vertical side frames.

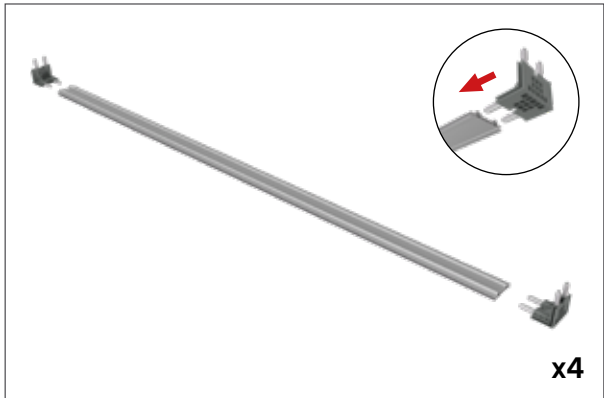

Step 4: Build the center power pole by push sections together. Slide on horizontal support clamp before attaching to frame. **Important! Horizontal support clamp may be preinstalled. If not, center and tighten screw in Step 8.**

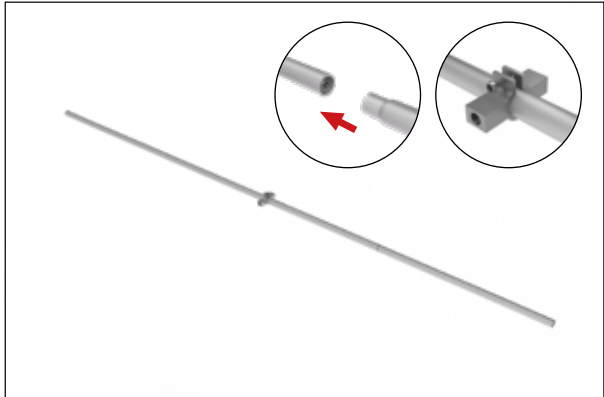

Step 5: Join the 2 vertical side frames to top and bottom horizontal frames while placing the center support pole into position.

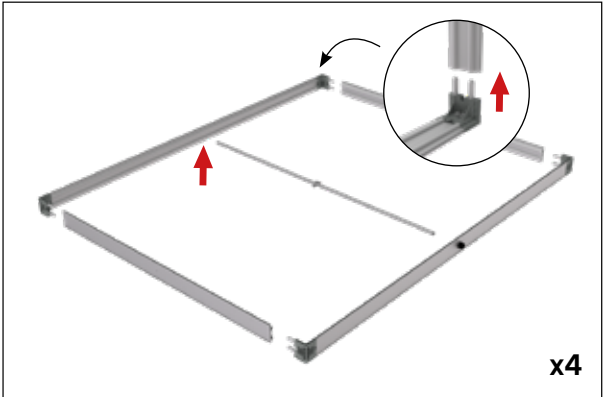

Set Up Instructions

DFW-3000L

Step 6: Screw one black horizontal cross support pole into each side of frame.

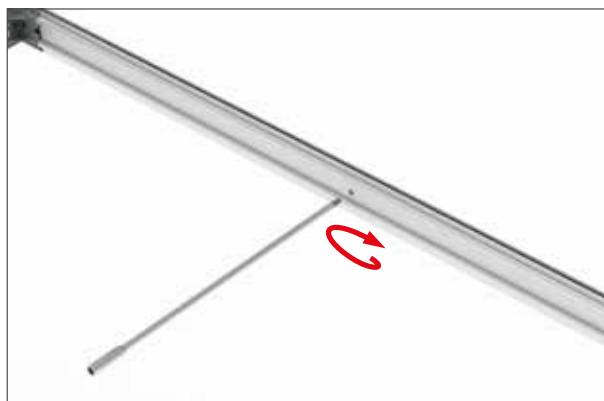

Step 7: Complete connections of horizontal cross support poles.

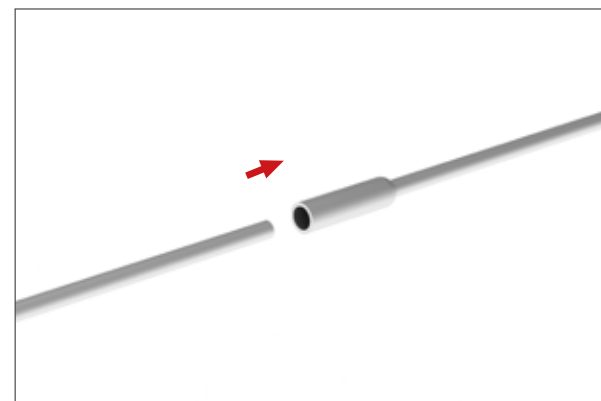
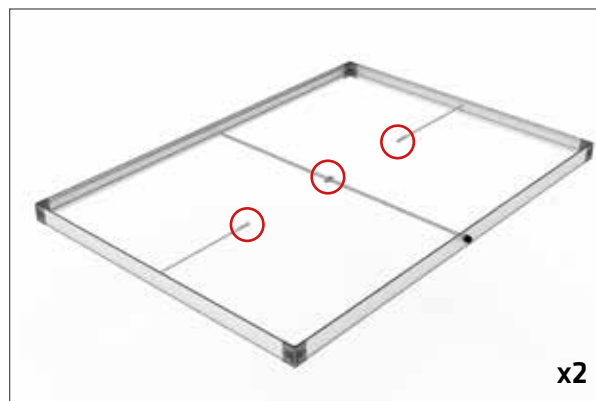

Step 8: Tighten center pole clamp to lock horizontal cross support poles into place. **Important!** If your center pole clamp was preinstalled, then skip this step.

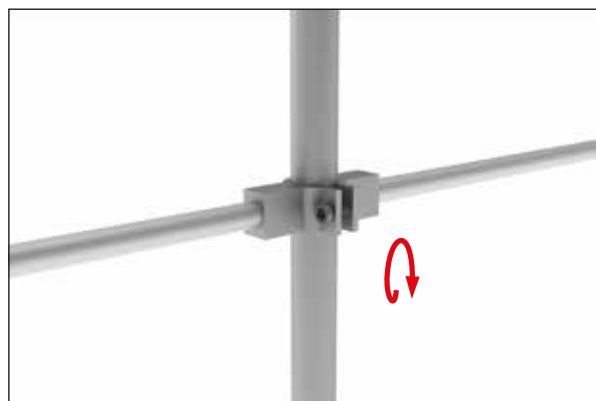

Set Up Instructions

DFW-3000L

Step 9: To install a graphic start by inserting one eSEG™ Fabric Print into 4 corners of frame by pressing silicone into frame edge.

The fabric stretches on a diagonal and is easier to install by following Step 10.



Step 10: Start in top corner (1) and then insert graphic into opposite bottom corner (2). Repeat on other side (3) and then (4). Then insert the graphic into center of each side and work back toward the corners.

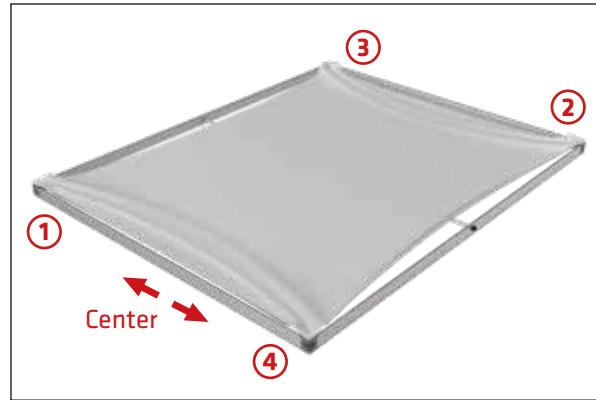

Step 11: Repeat Step 6-7 for the reverse side of frame.



Step 12: Screw feet into 2 bottom corners using hex tool provided.

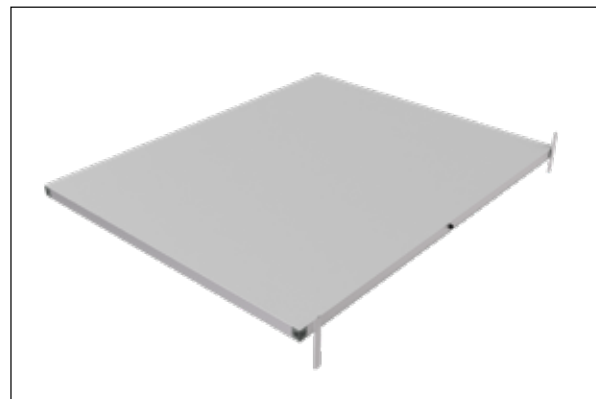
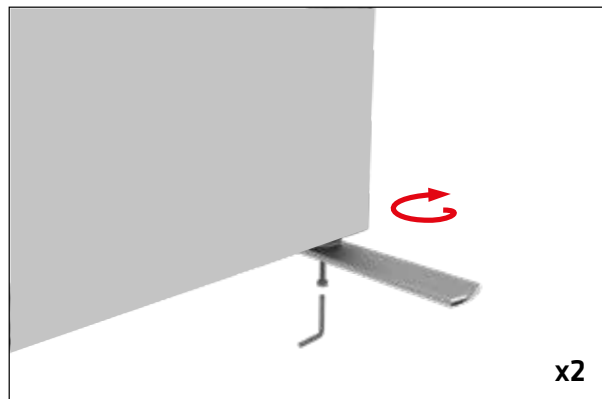

Step 13: Stand into upright position using one person on each side to lift display.

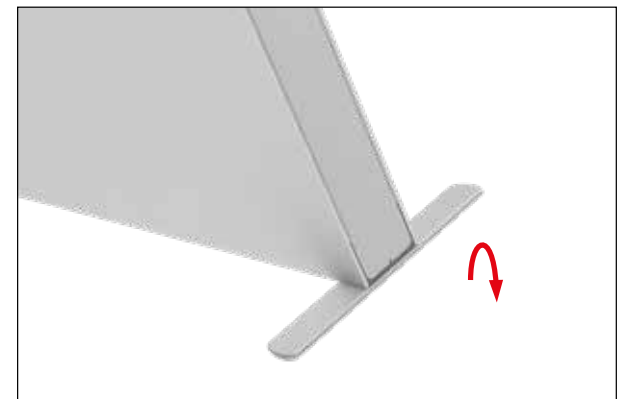

Set Up Instructions

DFW-3000L

OPTIONAL: Unroll frame covers and slide them into the groove of the frame from top to bottom. For use with one stand or on the outer two edges of multiple stands when connected together.



OPTIONAL: Connect frames together using u-clamp to create a continuous wall.

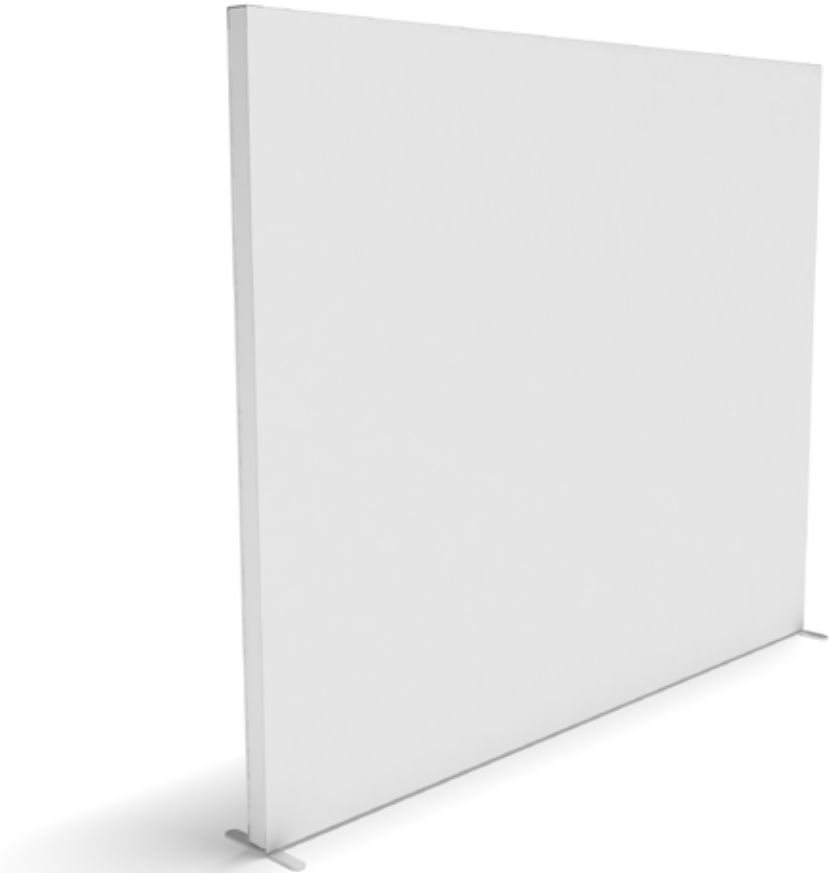
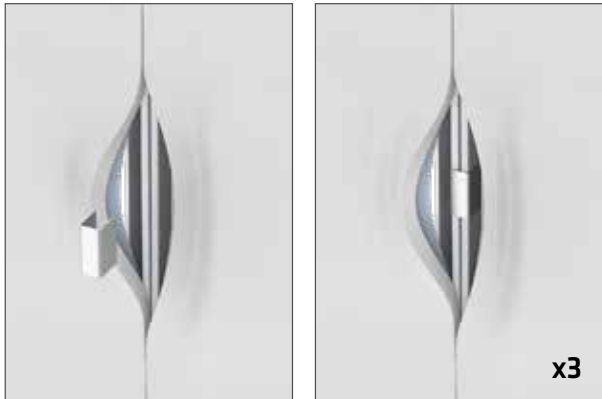

Set Up Instructions

DFW-1400L

Step 1: Open soft molded case and remove x2 vertical side frames with lights.



Step 2: Push sections together to complete each vertical side frame.

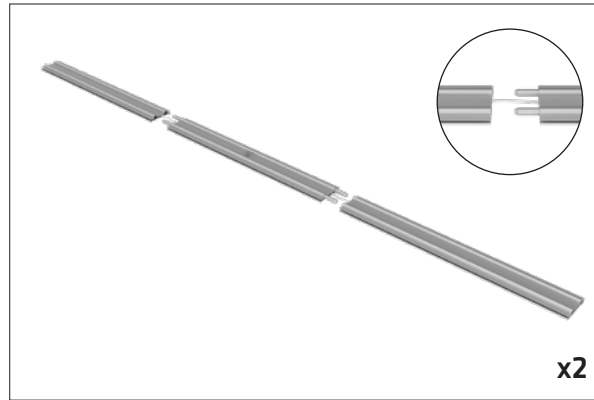

Step 3: Add 4 corners to the two vertical side frames.

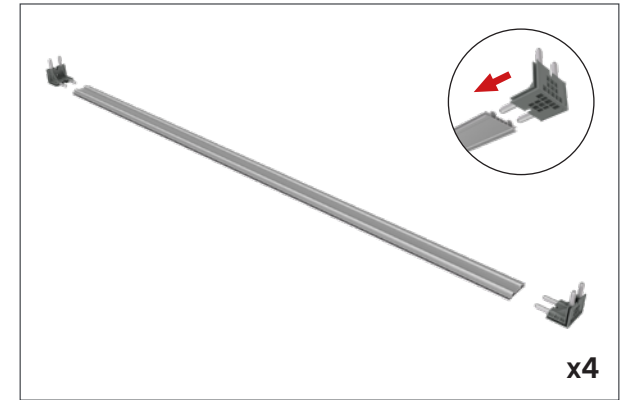

Step 4: Join the 2 vertical side frames to top and bottom horizontal frames.

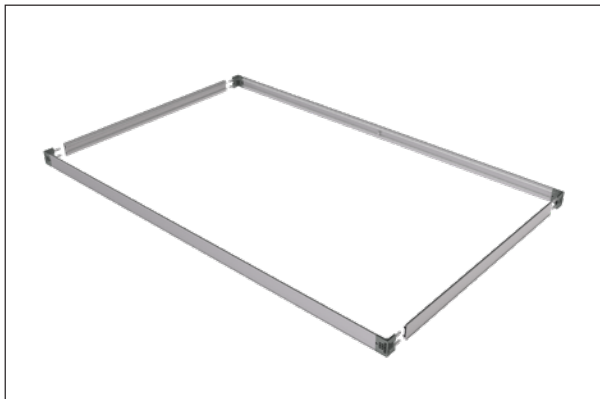

Step 5: Insert center support pole into center of vertical side frames.

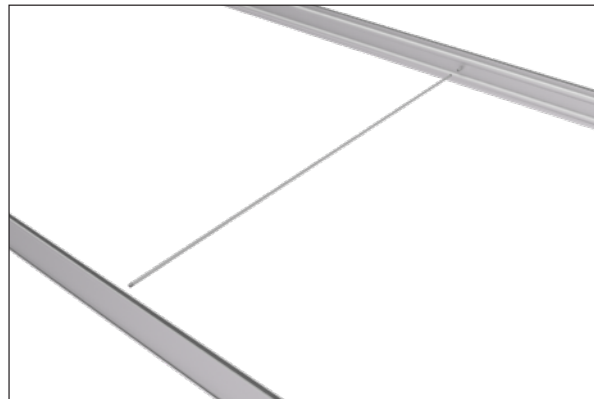

Place frame on top of ground cloth before moving forward and installing graphics.

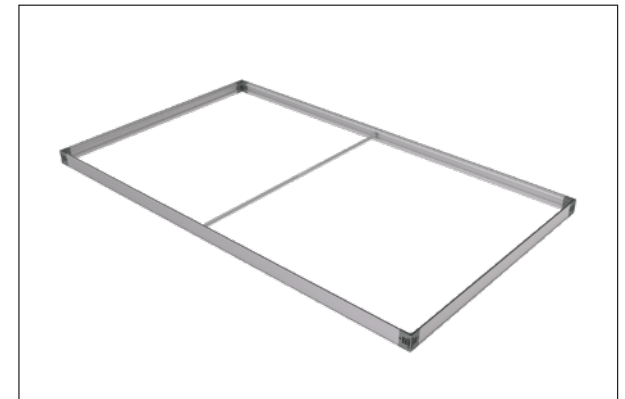

Set Up Instructions

DFW-1400L

Step 6: To install a graphic start by inserting one eSEG™ Fabric Print into 4 corners of frame by pressing silicone into frame edge.

The fabric stretches on a diagonal and is easier to install by following Step 7.

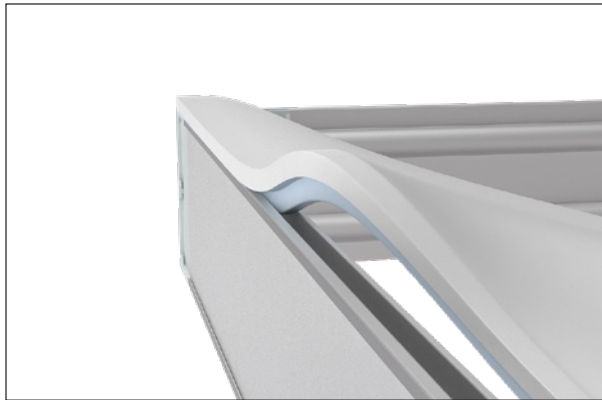

Step 7: Start in top corner (1) and then insert graphic into opposite bottom corner (2). Repeat on other side (3) and then (4). Then insert the graphic into center of each side and work back toward the corners.

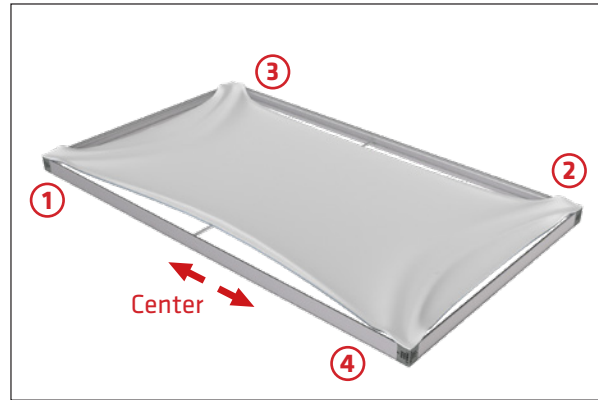

Step 8: Repeat Step 6-7 for the reverse side of frame.

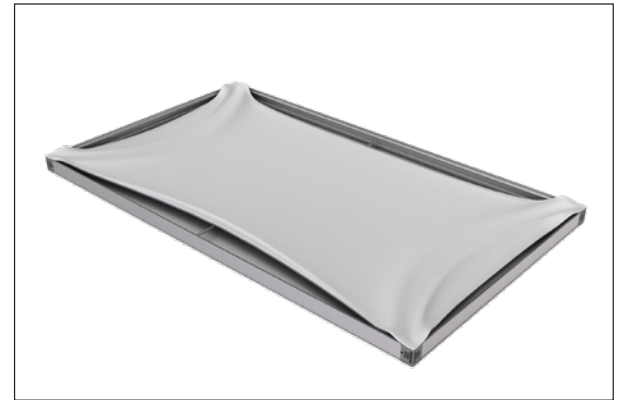

Step 9: Screw feet into 2 bottom corners using hex tool provided.

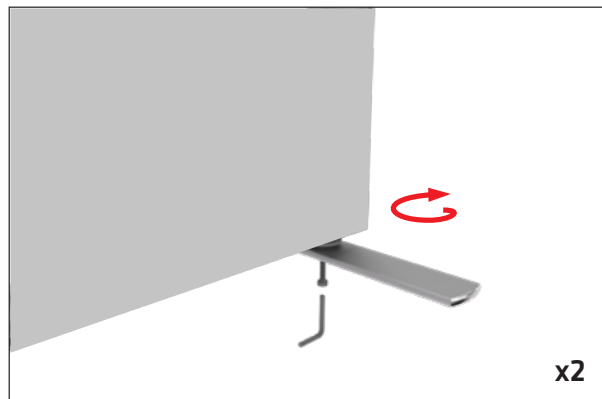

Step 10: Stand into upright position using one person on each side to lift display.

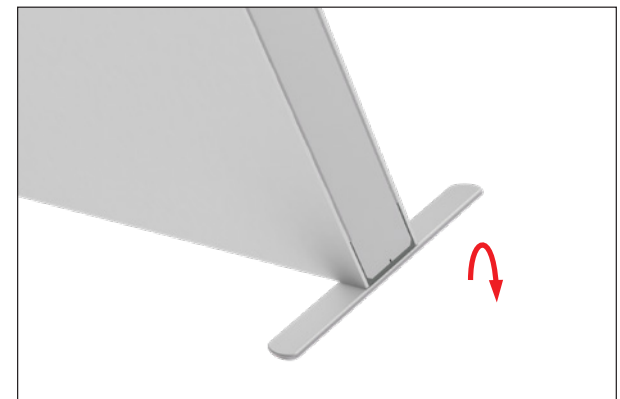
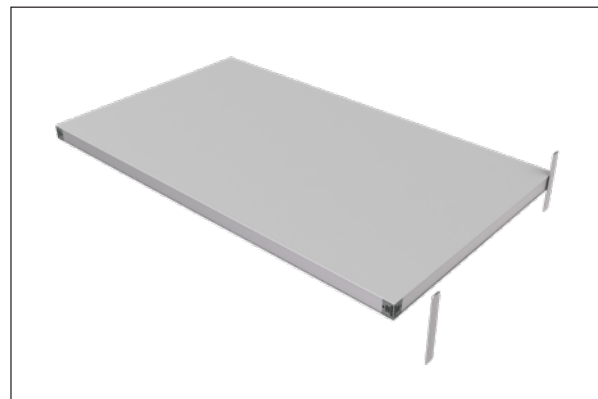

Set Up Instructions

DFW-1400L

OPTIONAL: Unroll frame covers and slide them into the groove of the frame from top to bottom. For use with one stand or on the outer two edges of multiple stands when connected together.



OPTIONAL: Connect frames together using u-clamp to create a continuous wall.

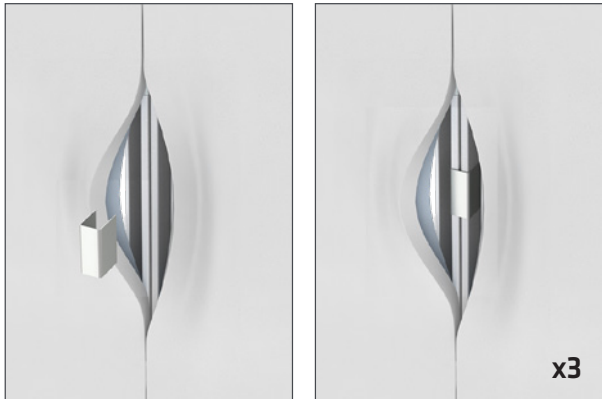

Set Up Instructions

DNA MONITOR MOUNT

Step 1: Preassemble the frame following the frame set up instructions included with the display.



Step 2: Remove black rubber plugs from the frame to reveal holes. Install cross bar into frame with screws and hex tool.

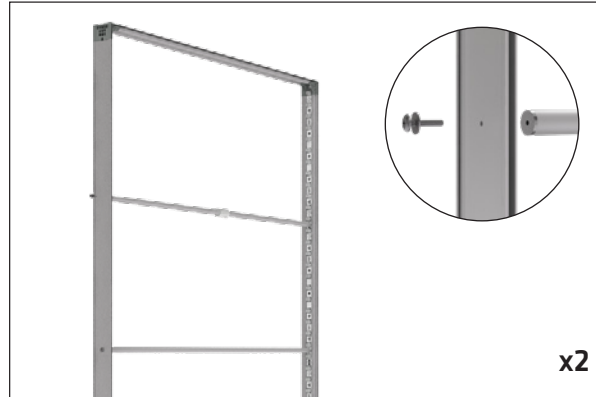

Step 3: Attach the top section of the hanging monitor pole to the center of the cross bar using the hex tool. Tighten securely.



Step 4: Intall front graphic. Refer to your display set-up instructions for this step. Holes in graphic should align close to hanging monitor pole.



Step 5: install the VESA Plate. Place screws through VESA plate, spacer, and graphic before screwing into hanging monitor pole. Tighten securely.

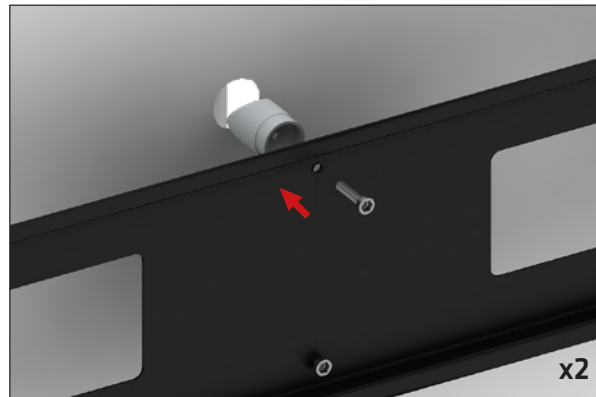

Step 6: Align monitor with bracket to set into place.

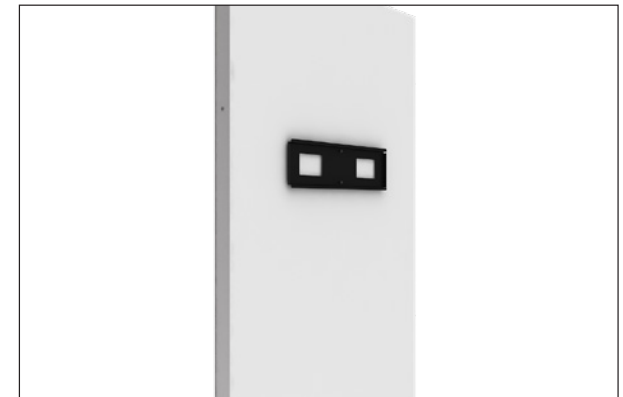

Set Up Instructions

DNA MONITOR MOUNT

Step 7: Attach brackets to back of monitor with screws. Rubber spacers can be placed between the bracket and the monitor if your the back of the monitor is not flat. Choose the spacer that best fits your need. Position the VESA bracket with the **hook facing down**.



Step 8: (A) Hang the monitor onto base plate to test the positioning. Once position is correct remove monitor and add graphic to frame.



Step 9: (B) Hang the monitor again and put in final screws to hold monitor bracket in place.

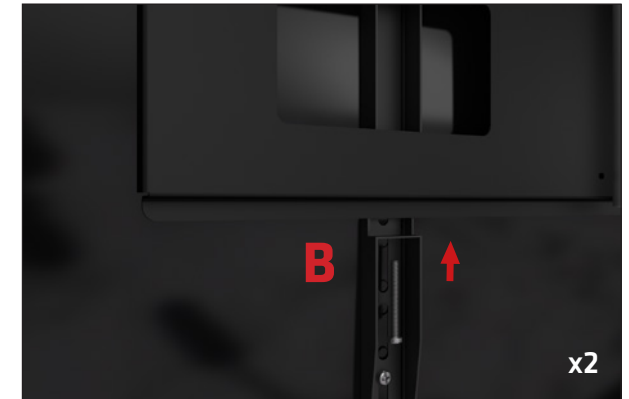

Step 10: Align monitor with bracket to set into place.



Step 11: Run power cord for monitor inside front graphic and install back graphic. Run power cord out of the bottom hole of back graphic.

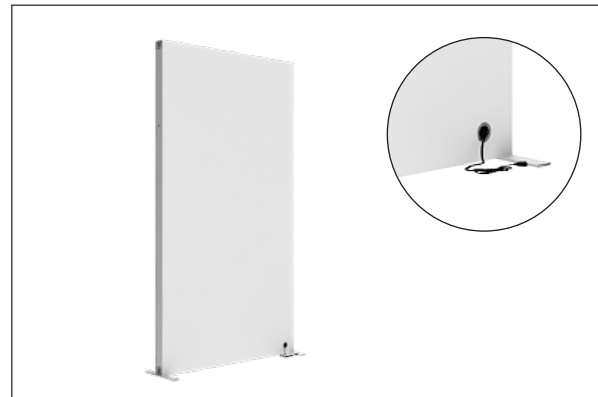

Set Up Instructions

MDSR-36089FS

Step 1: Assemble straight poles by pressing and pushing together.

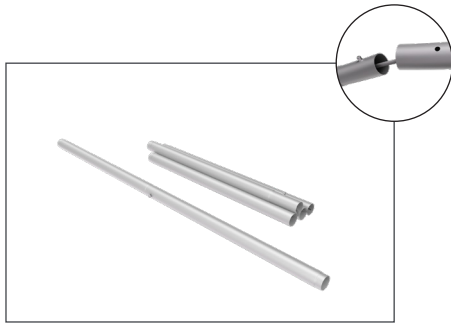

Step 2: Connect all corner sections to straight sections. Face holes of 90° corners towards the bottom of frame.

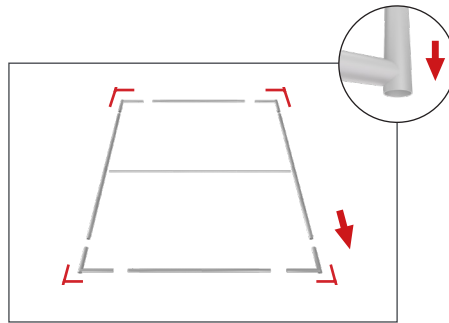

Step 3: Insert center support pole.

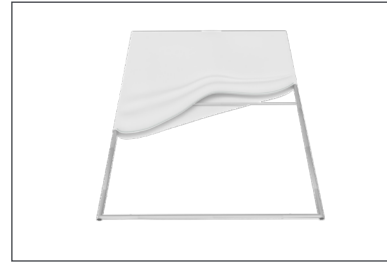

Step 4: Grip the fabric tightly and stretch around bottom pole to pinch zipper into place. Zip the graphic together for taut finish.

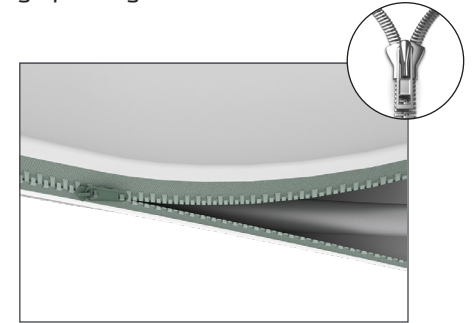

Step 5: Assemble post (75) into the 4 corners of the base plate with screw by hand turning post and tightening into place.

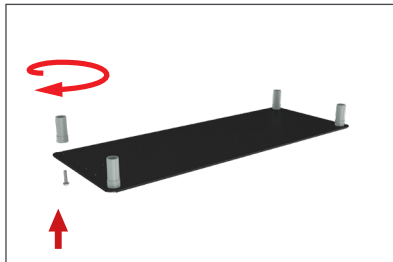

Step 6: Push banner stand frame onto back posts of flat base or optional feet. Press evenly on both sides to make easier for the frame to go on.

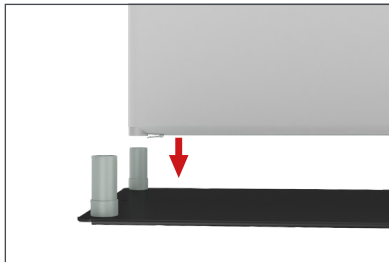

Step 7: Assemble x2 - (85) and (87) together and push poles into top of frame and front two posts (75).

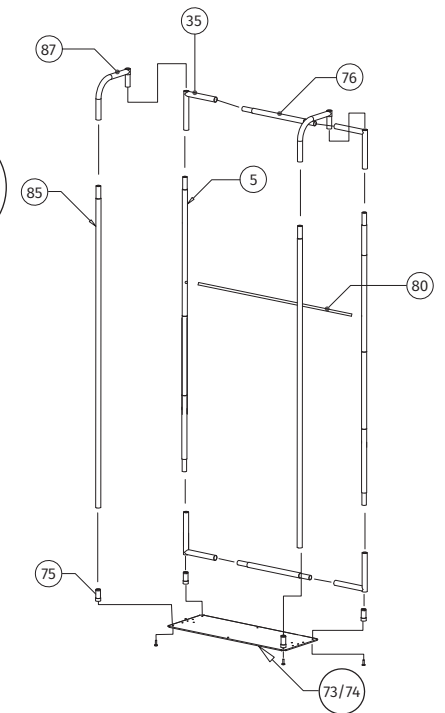
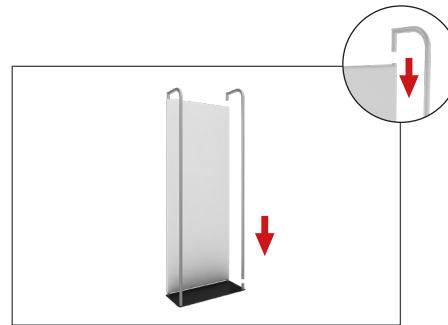

SHELVING & ACCESSORIES:
(OPTIONAL) To add shelves or accessories to frame, position and level part on frame before tightening clamps down with hex tool.



Set Up Instructions

CA700-CASE TO COUNTER

Step 1: Put case flat on the floor and undo straps. Lift lid and remove the contents of the case.

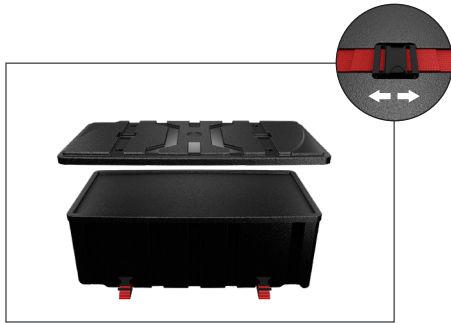

Step 2: Put the lid on the floor and screw the supplied vertical support poles into place.

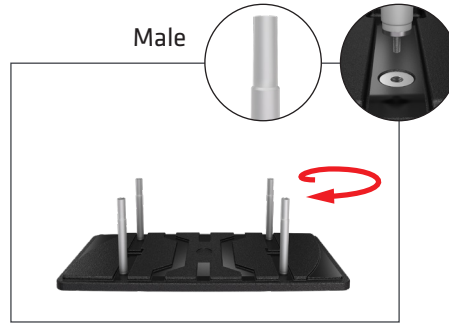

Step 3: Put the base on the floor with wheels up and screw the supplied vertical support poles into place.

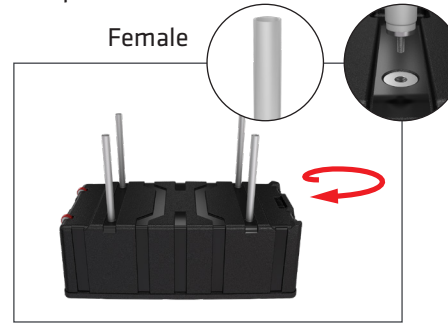

Step 4: Align support poles and fit the base to the lid. Press together firmly to secure. **OPTIONAL:** Install storage pocket onto lid first.

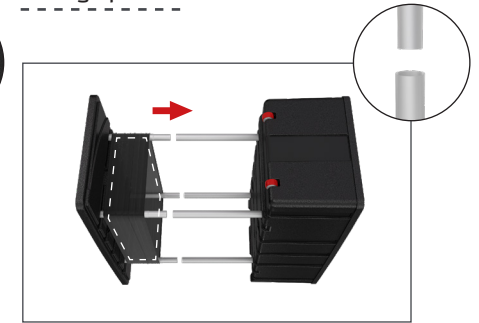

Step 5: Place case in a clean area upside down to place fabric print, over the case. **Start at the top with graphic up side down**, make sure zipper is in the middle.

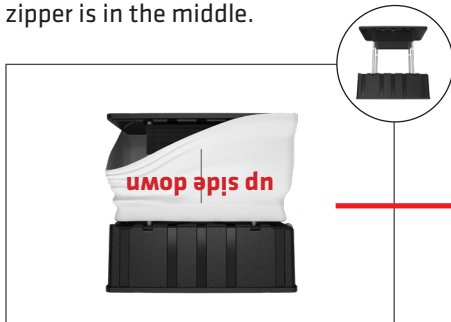

Pull the silicone grooved edge of graphic over the top of the lid and push onto the edge. Push the groove all the way around the case until secured without overstretching.

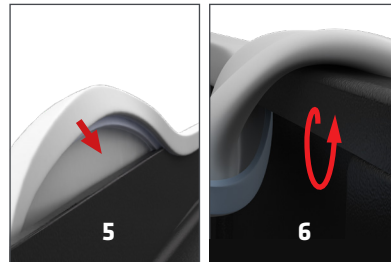

Step 6: Upright the case and pull edge of graphic over the top of the base and tuck under the lip into the groove of case. Follow all the way around the case until secured.



Step 7: Make sure that all wrinkles are out and the fabric looks straight. Press the counter top onto the case to secure.

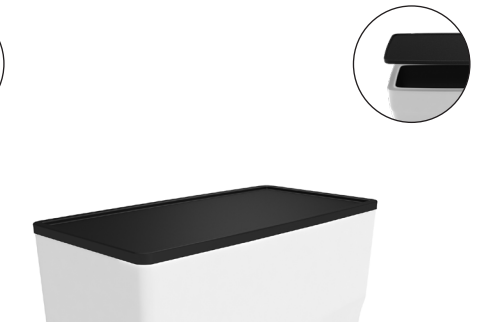

Note: Do not overstretch silicone edge when installing graphic or you will end up with extra fabric that will not press on.

STORAGE:
The zipper on the back is used to access storage.

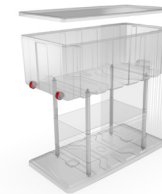
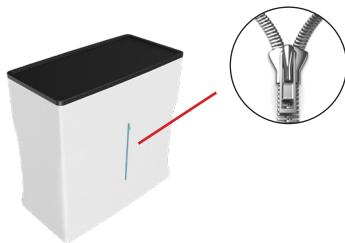

Set Up Instructions

PARROT

Step 1:

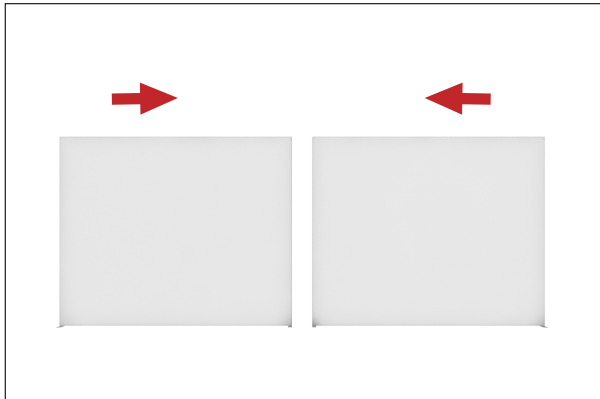

Step 2:

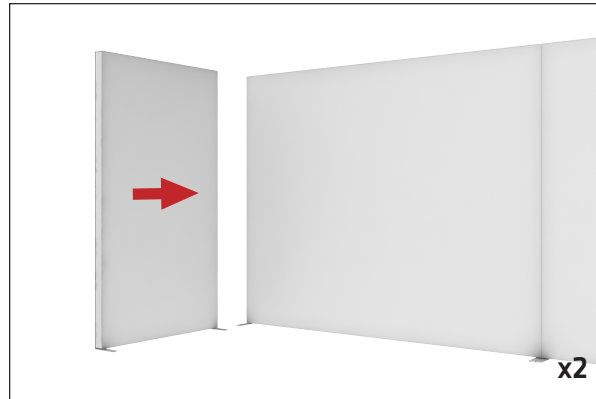

Step 3:

